



ELECTRIC DRINKING FOUNTAIN

A131.8 Series

MODEL A131408S

BARRIER FREE, WALL MOUNTED ELECTRIC DRINKING FOUNTAIN

STANDARD FEATURES

- Child or Adult ADA Compliant (when properly installed)
- 14 gage, 304 stainless steel
- Polished stainless steel, anti-rotation, non-squirt bubbler
- 100 mesh inlet strainer
- Vandal resistant screws
- Integral P-trap
- Mounting frame
- Back panel and louvered grille

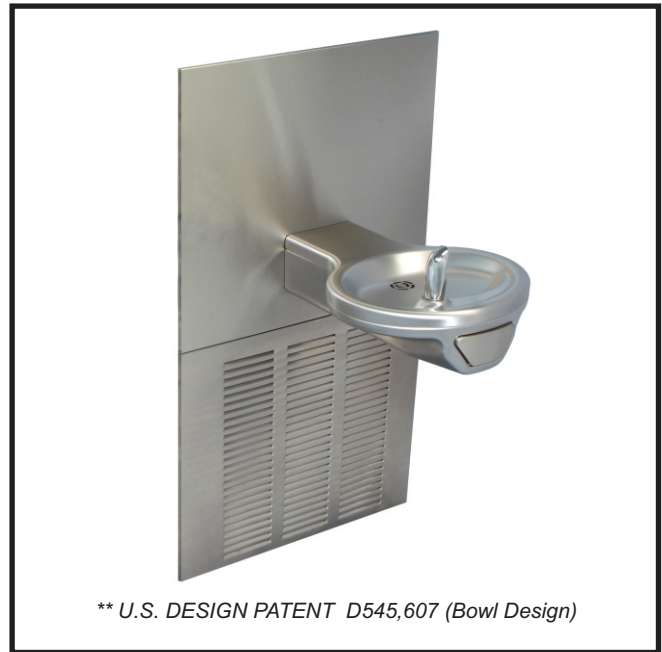

** U.S. DESIGN PATENT D545,607 (Bowl Design)

“INDOOR USE ONLY”

SUGGESTED SPECIFICATIONS

Model A131408S is a wall mounted, pressurized electric drinking fountain that shall deliver a minimum of **8.0 GPH** (30.3 LPH) of water at 50°F (10°C) cooled from 80°F (26.7°C) inlet water and 90°F (32.2°C) ambient. Unit shall be made from 18 gage, 304 stainless steel with a brushed finish. Unit shall be activated by a self-closing, frontal push pad, by using less than 5 pounds of force, which activates an internally mounted valve with an adjustable stream regulator controlling the water flow. Cooling system shall use R-134a refrigerant and be capillary tube regulated. An adjustable thermostat with an off position shall regulate the refrigeration system. Bubbler shall be polished stainless steel with a non-squirt feature and operate on a water pressure range of 20-105 psig. Unit shall have a uniquely designed, two-piece contoured bowl with P-trap integral to the unit. Unit shall be listed by Underwriters Laboratories for both the US and Canada and is compliant to the Air Conditioning and Refrigeration Institute Standard 1010. Unit is certified to ANSI A117.1, Public Law 111-380 (NO-LEAD), CHSC 116875 and NSF/ANSI 61, Section 9. Fixture meets ADA, ADA Standing Person, and ADA Child requirements when mounted appropriately.

MODEL:

(Must Specify)

FLEXIBLE BUBBLER (LOW FLOW)

- A131208F Bronze Finish
- A131308F Gold Finish (High Polish)
- A131408F Satin stainless Finish

LEAD-FREE STAINLESS STEEL BUBBLER

- A131208S Bronze Finish
- A131308S Gold Finish (High Polish)
- A131408S Satin stainless Finish (Shown)

OPTIONS

(additional costs may be incurred)

- HP High polished stainless steel
- WF1 1500 gallon capacity, NSF 42+53, 1 micron lead reduction filter
- 220V 220 volt / 50 Hz compressor (€ €)

Model Number	GPH*	Rated Watts	Full Load Amps	Approx. Shipping Weight
A131408S	8.0	390	4.6	90 lbs.

*GPH of 50°F water at 90°F ambient room temperature and 80°F inlet water temperature. Compressor motor operates on 115 Volt / 60 Hz single phase.



Member of U.S. Green Building Council



Recyclable Product



Water Conserving Product

Complies with the following standards:



NSF/ANSI 61



GREEN U.P.C. Water Efficiency



Federal Public Law 111-380 (No Lead)



CHSC 116875



UL US

Test rating conditions are compliant with ARI 1010.

Please visit www.murdockmfg.com for most current specifications.

MURDOCK MFG. • 15125 Proctor Avenue • City of Industry, CA 91746 USA
Phone 800-453-7465 or 626-333-2543 • Fax 626-855-4860 • www.murdockmfg.com

Member of MORRIS GROUP INTERNATIONAL



ELECTRIC DRINKING FOUNTAIN

All dimensions are subject to manufactures tolerance of plus or minus 1/8" nominal and subject to change without notice. Murdock Mfg. assumes no responsibility for use of void or superseded data. Dimensions may change with the addition of optional accessories. Murdock Mfg.™, Member of Morris Group International™. Please visit www.Murdockmfg.com for most current specifications.

A131.8 Series MODEL A131408S BARRIER FREE, WALL MOUNTED ELECTRIC DRINKING FOUNTAIN

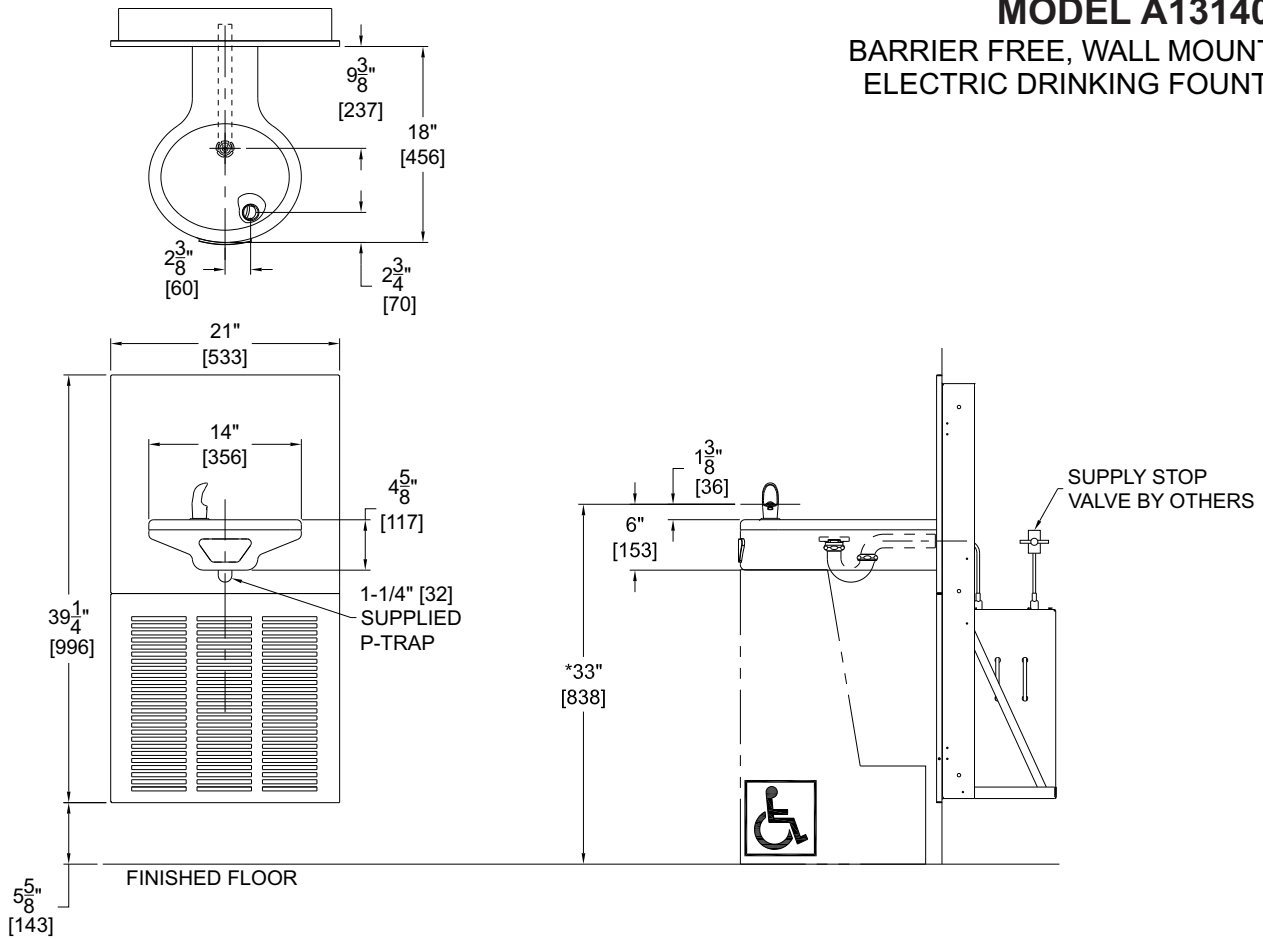

GENERAL NOTES:

1. ALL DIMENSIONS ARE IN INCHES [MM].
- *2. DIMENSIONS SHOWN ARE FOR RECOMMENDED ADULT HEIGHT. ADJUST VERTICAL DIMENSIONS AS NECESSARY TO COMPLY WITH FEDERAL, STATE, & LOCAL CODES.
3. WATER LINE FROM CHILLER TO FOUNTAIN SHOULD BE COVERED WITH SPONGE FOAM RUBBER OR ICE WATER TYPE INSULATION OF ADEQUATE THICKNESS.

Murdock Mfg.™ warrants that its products are free from defects in material or workmanship under normal use and service for a period of one year from date of shipment. Murdock's liability under this warranty shall be discharged solely by replacement or repair of defective material, provided Murdock™ is notified in writing within one year from date of shipment, F.O.B. Industry, California.

SELECTION SUMMARY & APPROVAL FOR MANUFACTURING	Model Number & Options _____	Quantity _____	All dimensions are subject to manufactures tolerance of plus or minus 1/8" nominal and subject to change without notice. Murdock assumes no responsibility for use of void or superseded data. Dimensions may change with the addition of optional accessories. Murdock Mfg.™, Member of Morris Group International™. Please visit www.murdockmfg.com for most current specifications.
	Company _____		
	Contact _____	Title _____	
	Signature (Approval for Manufacturing) _____	Date _____	

MURDOCK MFG. • 15125 Proctor Avenue • City of Industry, CA 91746 USA
Phone 800-453-7465 or 626-333-2543 • Fax 626-855-4860 • www.murdockmfg.com

Member of
MORRIS GROUP INTERNATIONAL